

TIME-SERT®

THREAD REPAIR KIT

With Tap guide

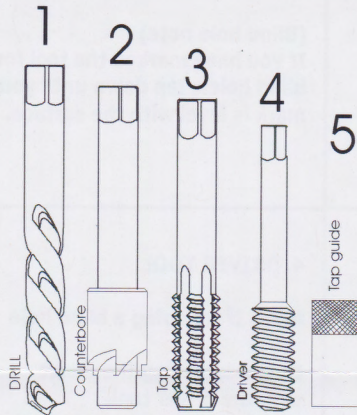

KIT CONTENTS

1. Drill
2. Counterbore
3. Tap
4. Driver
5. Tap guide

Use WD40 when drill & tapping

-WARNING-

Cutting tools may shatter if broken. The wearing of safety glasses is required in the vicinity of their use.

(BLIND HOLES: Measuring for depth)

If the hole is a blind hole repair (does not pass thru) Read below note.
As a basic rule for blind holes the insert should be $\frac{1}{4}$ inch or 6mm shorter than the hole depth.

A) Start by measuring the depth of the hole.

B) Mark the drill, tap, driver tools so you do not bottom out tools in hole.

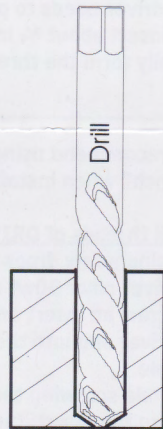

1. DRILL out old threads keeping drill square to surface of hole.

(Blind hole note)

If you have marked the drill for blind holes, drill down until your mark is level with the surface.

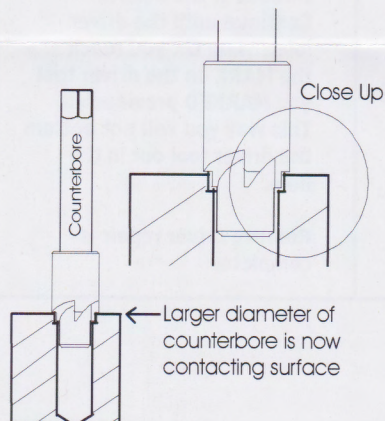

2. COUNTERBORE the hole to the full depth permitted by the tool. The counterbore tool has 4 cutting teeth and a larger diameter that is the stop.

When the larger diameter contacts the surface a full 360 degrees this is the full depth.

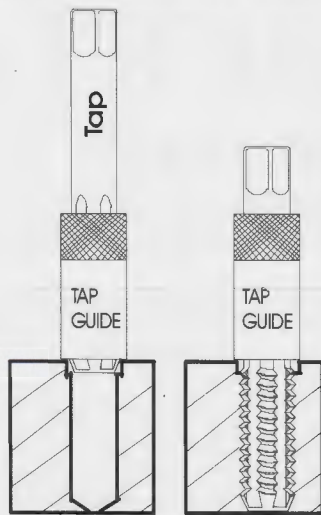

We recommend using a "tap wrench" when tapping holes.

3. TAP new threads to the full depth of hole. Use the TAP GUIDE included to ensure the threads are square to surface.

Note: Hold tap guide firmly. Watch that the tap guide remains flush when tapping.

(Blind hole note)

If you have marked the tool for blind holes, tap down until your mark is level with the surface.

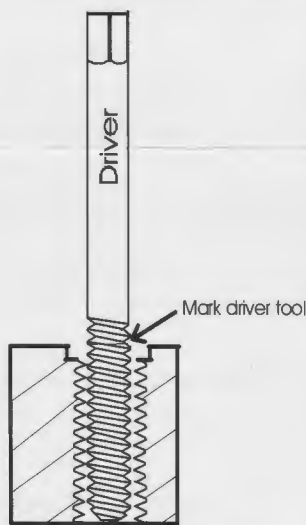

4. DRIVER TOOL

Note: If repairing a blind hole

Before installing the insert with the driver tool. Place the driver in the hole to touch the bottom of hole and MARK the driver so you have a visual Mark to know where the bottom of the hole is. You do not want to bottom the driver tool out in the hole on installation.

The driver needs to pass thru the insert about 1/4 inch or 6mm to fully form the threads.

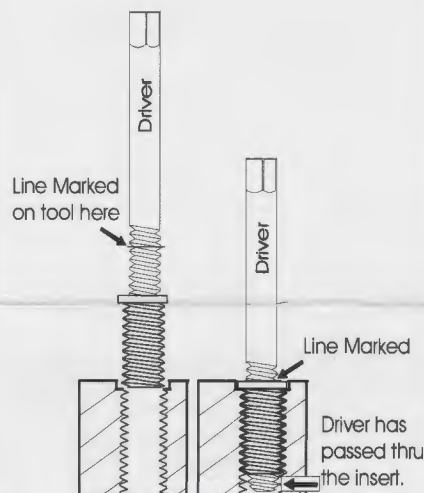

We recommend using a "tap wrench" when installing inserts

5. Oil threads of DRIVER TOOL

Using a few drops of insert driver oil or 30wt motor oil. Screw an insert onto the Driver and into the prepared hole.

While screwing the driver thru the insert, the driver will start to tighten up as it expands the bottom few threads of the insert.

Continue until the driver loosens up OR you reach the MARK on the driver tool you MARKED previously. This way you will not bottom the driver tool out in the hole.

Remove driver repair is complete.